

# SCXI™-1321 OFFSET-NULL AND SHUNT-CALIBRATION HIGH-VOLTAGE TERMINAL BLOCK

This guide describes how to install and use the SCXI-1321 offset-null and shunt-calibration terminal block with your SCXI-1121 module.

## Introduction

---

You can only use the SCXI-1321 terminal block with SCXI-1121 revision C and later revisions. The SCXI-1321 terminal block has a shielded board with supports for connection to the SCXI-1121 input connector. In addition to the 18 screw terminals, the SCXI-1321 has circuitry for offset-null adjustment of Wheatstone bridges, and a shunt resistor for strain-gauge shunt calibration. This terminal block was primarily designed for bridge-type transducers such as strain gauges. The SCXI-1321 can also easily accommodate thermocouples, RTDs, thermistors, millivolt sources, volt sources, and current-loop receivers.

## What You Need to Get Started

---



To set up and use your SCXI-1321, you need the following items:

- SCXI-1321 offset-null and shunt-calibration terminal block
- SCXI-1321 Offset-Null and Shunt-Calibration High-Voltage Terminal Block Installation Guide*
- SCXI chassis
- SCXI-1121 module
- Number 1 and 2 Phillips-head screwdrivers
- 1/8 in. flathead screwdrivers

- Long-nose pliers
- Wire cutter
- Wire insulation stripper

## Conventions

---

	The following conventions are used in this guide:
	This icon denotes a note, which alerts you to important information.
	This icon denotes a caution, which advises you of precautions to take to avoid injury, data loss, or a system crash.
<i>italic</i>	Italic text denotes variables, emphasis, a cross reference, or an introduction to a key concept. This font also denotes text that is a placeholder for a word or value that you must supply.
monospace	Text in this font denotes text or characters that you should enter from the keyboard, sections of code, programming examples, and syntax examples. This font is also used for the proper names of disk drives, paths, directories, programs, subprograms, subroutines, device names, functions, operations, variables, filenames and extensions, and code excerpts.
<i>monospace italic</i>	Italic text in this font denotes text that is a placeholder for a word or value that you must supply.

## Safety Information

---



**Cautions** *Do not operate the device in an explosive atmosphere or where there may be flammable gases or fumes.*

*Keep away from live circuits.* Do not remove equipment covers or shields unless you are trained to do so. If signal wires are connected to the device, hazardous voltages may exist even when the equipment is turned off. To avoid a shock hazard, do *not* perform procedures involving cover or shield removal unless you are qualified to do so and disconnect all field power prior to removing covers or shields.

Equipment described in this document must be used in an Installation Category II environment per IEC 664. This category requires local level supply mains-connected installation.

*Do not operate damaged equipment.* The safety protection features built into this device can become impaired if the device becomes damaged in any way. If the device is damaged, turn the device off and do *not* use until service-trained personnel can check its safety. If

necessary, return the device to National Instruments for service and repair to ensure that its safety is not compromised.

Do not operate this equipment in a manner that contradicts the information specified in this document. Misuse of this equipment could result in a shock hazard.

Terminals are for use only with equipment that has no accessible live parts.

*Do not substitute parts or modify equipment.* Because of the danger of introducing additional hazards, do *not* install unauthorized parts or modify the device. Return the device to National Instruments for service and repair to ensure that its safety features are not compromised.

When using the device with high common-mode voltages, you *must* insulate your signal wires for the highest input voltage. National Instruments is not liable for any damages or injuries resulting from inadequate signal wire insulation. Use only 26-14 AWG wire with a voltage rating of 300 V and 60 °C for measuring up to 300 V.

When connecting or disconnecting signal lines to the SCXI terminal block screw terminals, make sure the lines are powered off. Potential differences between the lines and the SCXI ground create a shock hazard while you connect the lines.

Connections, including power signals to ground and vice versa, that exceed any of the maximum signal ratings on the SCXI device can create a shock or fire hazard or can damage any or all of the boards connected to the SCXI chassis, the host computer, and the SCXI device. National Instruments is *not liable for any damages or injuries* resulting from incorrect signal connections.

If high voltages ( $\geq 30 V_{\text{rms}}$  and  $42.4 V_{\text{peak}}$  or 60 VDC) are present, you must connect a safety earth ground wire to the terminal block safety ground solder lug, shown in Figure 1. This complies with safety agency requirements and protects against electric shock when the terminal block is not connected to the chassis. To connect the safety earth ground to the safety ground solder lug, run an earth ground wire in the cable from the signal source to the terminal block. National Instruments is *not liable for any damages or injuries* resulting from inadequate safety earth ground connections.

Do *not* loosen or re-orient the safety ground solder lug hardware when connecting the safety ground wire; to do so reduces the safety isolation between the high voltage and safety ground.

# Temperature Sensor Output and Accuracy

The temperature sensor outputs 10 mV/°C and has an accuracy of  $\pm 0.9$  °C over the 0 to 55 °C temperature range. To determine the temperature, use the following formulas:

$$T (^{\circ}\text{C}) = 100 \times V_{\text{TEMPOUT}}$$

$$T (^{\circ}\text{F}) = T (^{\circ}\text{C}) \times 9/5 + 32$$

where  $V_{\text{TEMPOUT}}$  is the temperature sensor output voltage, and  $T (^{\circ}\text{F})$  and  $T (^{\circ}\text{C})$  are the temperature readings in degrees Fahrenheit and degrees Celsius, respectively.



**Note** Use the average of a large number of samples to obtain the most accurate reading. Noisy environments require averaging for greater accuracy.

## Using the Nulling Circuitry and the Shunt Calibration

### SCXI-1321 Nulling Circuitry

The nulling circuitry operates with full-bridge, half-bridge, quarter-bridge, and strain-gauge configurations. Each channel has its own nulling circuitry and its own trimming potentiometer as listed in Table 1.

**Table 1.** Trimmer Potentiometers and Corresponding Channels

Channel Number	Trimmer Potentiometer
0	R1
1	R2
2	R14
3	R15

To null the static offset voltage of the bridge, use the following procedure:

1. Hook up your bridge configuration to the selected channel.
2. Select and read the channel output.
3. While monitoring the output, rotate the trimmer wiper with a flathead screwdriver until you reach 0 V.

You have nulled your bridge and are ready for a measurement.

The nulling range that is provided with your terminal block is  $\pm 2.5$  mV, assuming that you have a 120  $\Omega$  strain gauge quarter-bridge configuration

and 3.333 V excitation voltage. You can change this range by replacing the nulling resistor with a resistor your choice of another value. Each channel has an independent nulling resistor. You can therefore mix your ranges to accommodate each channel requirement. Table 2 lists the nulling resistors and their corresponding channels.

**Table 2.** Nulling Resistors and Corresponding Channels

Channel Number	Nulling Resistor
0	R3
1	R5
2	R7
3	R9

The value of all the nulling resistors on your terminal block is 39 kΩ.



**Note** These resistors are socketed for easy replacement. These sockets best fit a 1/4 W resistor lead size.

To determine your nulling range, use the following formula (refer to Figure 1 for visual help):

$$V_{\text{nulling range}} = \pm \left| \frac{V_{\text{exc}}}{2} - \frac{V_{\text{exc}} R_d (R_{\text{null}} + R_g)}{R_{\text{null}} R_g + R_d (R_{\text{null}} + R_g)} \right|$$

where

$R_g$  is the nominal strain-gauge resistance value.

$R_d$  is either a completion resistor or a second strain-gauge nominal resistance.

$R_{\text{null}}$  is the nulling resistor value.

$V_{\text{exc}}$  is the excitation voltage (3.333 V or 10 V).

For example, assuming:

$$V_{\text{exc}} = 3.333 \text{ V}$$

$$R_g = 120 \text{ } \Omega$$

$$R_d = 120 \text{ } \Omega$$

$$R_{\text{null}} = 39 \text{ k}\Omega$$

$$V_{\text{nulling range}} = \pm 2.56 \text{ mV}$$

Assuming a strain-gauge range with a gauge factor of  $GF = 2$  and a quarter-bridge configuration, this range corresponds to  $\pm 1,498 \mu\epsilon$  as given by the strain formula for a quarter-bridge strain gauge configuration:

$$\epsilon = \frac{-4V_r}{GF(1 + 2V_r)}$$

where

$$V_r = \frac{\text{strained voltage} - \text{static unstrained voltage}}{V_{exc}}$$

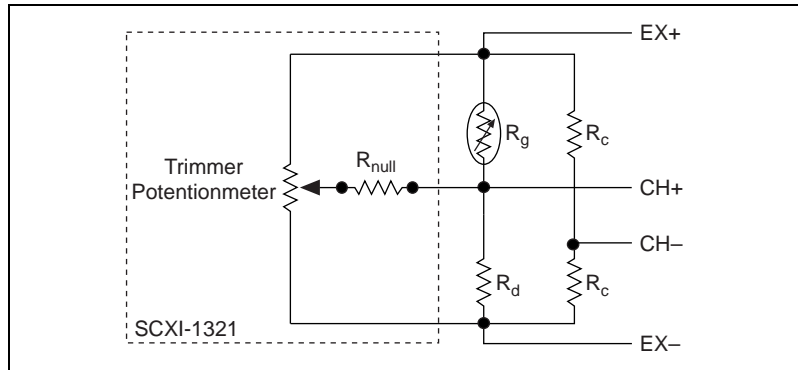

**Figure 1.** Nulling Circuit



**Note**  $R_c$  stands for the completion resistors.

## Using the SCXI-1321 with RTDs and Thermistors

When using this terminal block with RTDs or thermistor-type transducers and with the SCXI-1121 excitation set in the current mode, you must disable the nulling circuit of the channel of interest. You can do this in two steps:

1. Place the enable/disable jumper in position D (disable) as shown in Table 3.
2. Remove the nulling resistor from its sockets.

**Table 3.** Jumper Settings of the Nulling Circuits

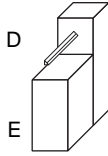
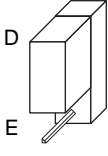
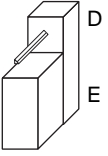
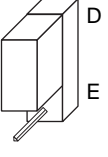
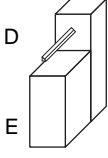
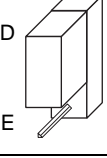
<b>Jumper</b>	<b>Position</b>	<b>Description</b>
W1		Nulling circuit of Channel 0 is enabled; factory setting
		Nulling circuit of Channel 0 is disabled
W2		Nulling circuit of Channel 1 is enabled; factory setting
		Nulling circuit of Channel 1 is disabled
W3		Nulling circuit of Channel 2 is enabled; factory setting
		Nulling circuit of Channel 2 is disabled

**Table 3.** Jumper Settings of the Nulling Circuits (Continued)

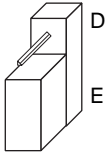
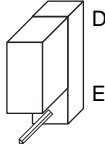
Jumper	Position	Description
W4		Nulling circuit of Channel 3 is enabled; factory setting
		Nulling circuit of Channel 3 is disabled

## SCXI-1121 Shunt Calibration

Shunt calibration circuits are independent from each other, but are controlled together. In other words, when SCAL is set to 1 on the SCXI-1121, all the shunt switches close. When SCAL is cleared to 0, all the switches open. At startup or reset, all switches are open. This shunt calibration circuitry configuration places a shunting resistor in parallel with the strain gauge, as shown in Figure 2.

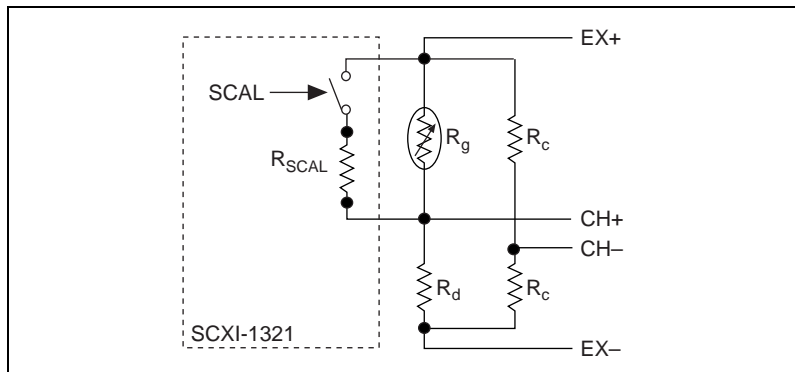

**Figure 2.** Shunt Circuit

The shunting resistors  $R_{SCAL}$  are socketed so that you can replace them with a resistor of another value to achieve the required changes. The  $R_{SCAL}$  provided on your terminal block have a  $301\text{ k}\Omega \pm 1\%$  value.

Assuming a quarter-bridge strain-gauge configuration with a gauge factor of  $GF = 2$ , the equivalent strain change introduced by the  $R_{SCAL}$  shunting resistor is  $-199\text{ }\mu\epsilon$ .



Use the following formula to determine the change due to this shunting resistor:

$$V_{\text{change}} = \frac{V_{\text{ex}} R_d (R_{\text{SCAL}} + R_g)}{R_g R_{\text{SCAL}} + R_d (R_{\text{SCAL}} + R_g)} - \frac{V_{\text{ex}}}{2}$$

Next, using the appropriate strain-gauge strain formula, and assuming that you have no static voltage, determine the equivalent strain the  $R_{\text{SCAL}}$  should provide. For example,  $R_{\text{SCAL}} = 301 \text{ k}\Omega$  and a quarter-bridge  $120 \text{ }\Omega$  strain gauge with a gauge factor of  $\text{GF} = 2$  and  $V_{\text{exc}} = 3.333 \text{ V}$  and  $R = 120 \text{ }\Omega$  produces the following:

$$V_{\text{change}} = 0.3321 \text{ mV}$$

Replacing the strained voltage by  $V_{\text{change}}$  in the quarter-bridge strain equation produces an equivalent  $199 \text{ }\mu\epsilon$  of change.

## Using Shunt Calibration with National Instruments Software

If you are using LabVIEW for Windows 2.5.2 or LabVIEW 3.0, use the channel string `shuntx` to enable shunt calibration. If you are using NI-DAQ or LabVIEW 2.2.1 or earlier versions, use the `SCXI_Calibrate_Setup` function or VI. If you are using register-level code to program the SCXI-1121 and the SCXI-1321, you must write to the SCAL register yourself.

## Signal Connection

---



**Note** Refer to the [Safety Information](#) section before removing equipment covers or connecting or disconnecting any signal wires.

When connecting your signals to the SCXI-1321, follow the labeling on the SCXI-1321 for the appropriate module, as indicated in Figure 2.

To connect the signal to the terminal block, perform the following steps, referring to Figures 1 and 2 as necessary:

1. Unscrew the top cover screws and remove the cover.
2. Loosen the strain-relief screws and remove the strain-relief bar.
3. Enable or bypass each of the nulling circuits, depending on the signal you are measuring.



**Note** For correct operation of the SCXI-1121 excitation channels, disable the nulling circuit on the excitation channels when you are using the SCXI-1321 with the SCXI-1121.

4. Run the signal wires through the strain-relief opening. You can add insulation or padding if necessary.
5. Prepare your signal wire by stripping the insulation no more than 7 mm.
6. Connect the wires to the screw terminals by inserting the stripped end of the wire fully into the terminal. No bare wire should extend past the screw terminal. Exposed wire increases the risk of shorting and causing a failure.
7. Tighten the screws to a torque of 5–7 in.-lb.
8. Connect safety earth ground to the safety-ground solder lug. Refer to the [Safety Information](#) section for connection information.
9. Reinstall the strain-relief bar and tighten the strain-relief screws.
10. Reinstall the top cover and tighten the top cover screws.
11. Connect the terminal block to the module front connector as explained in the [Installation](#) section.

Figure 3 shows the SCXI-1321 terminal block parts locator diagram.

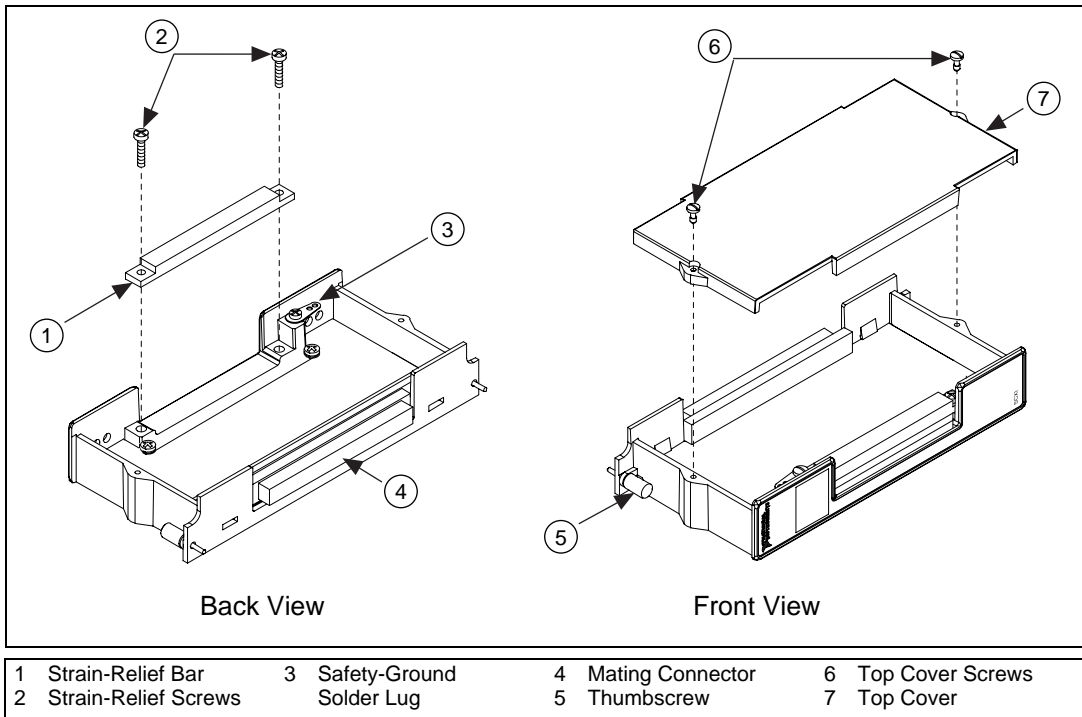

**Figure 3.** SCXI-1321 Parts Locator Diagram

Figure 4 shows the SCXI-1321 signal connections.

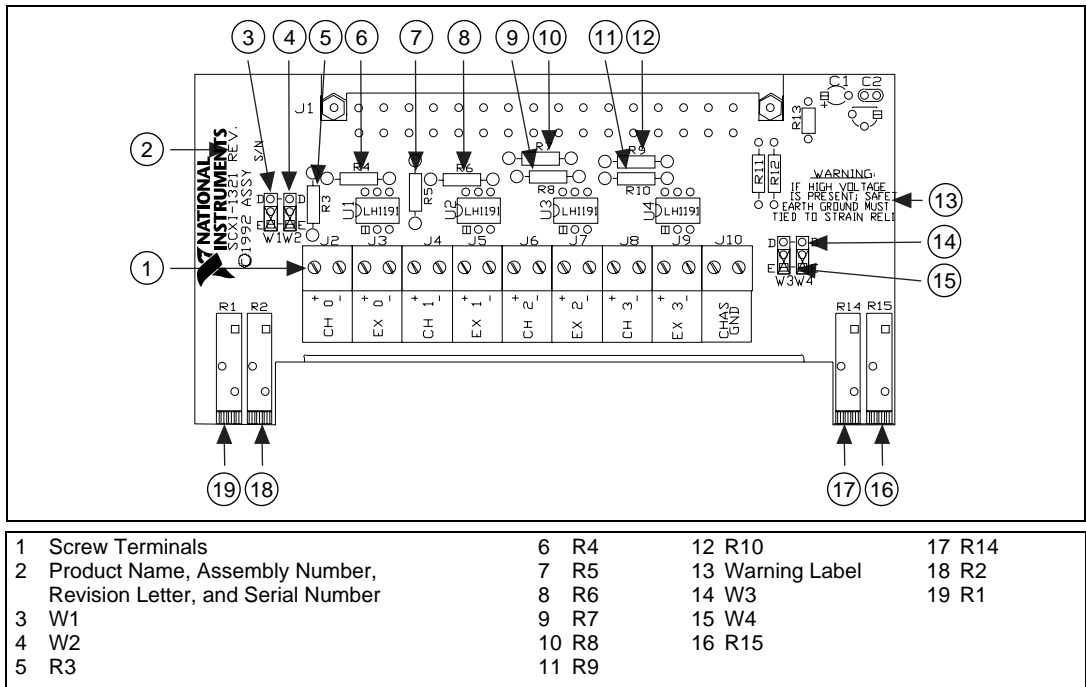

Figure 4. SCXI-1321 Signal Connections

## Installation

To connect the terminal block to the SCXI module front connector, perform the following steps:

1. Connect the module front connector to its mating connector on the terminal block.
2. Make sure that the module top and bottom thumbscrews do *not* obstruct the rear panel of the terminal block.
3. Tighten the top and bottom screws on the back of the terminal block to hold it securely in place.



**Note** To minimize the temperature gradient inside the terminal block, move the SCXI chassis away from any extreme temperature differential.

# Cleaning the Terminal Block

---

Clean the terminal block by brushing off light dust with a soft, nonmetallic brush. Remove other contaminants with deionized water and a stiff nonmetallic brush. The unit must be completely dry and free from contaminants before returning to service.

## Specifications

---

All specifications are typical at 25 °C unless otherwise specified.

### Cold-junction sensor

Accuracy<sup>1</sup> .....0.9 °C

Output .....10 mV/°C from 0 to 55 °C

### Common-mode isolation

Terminal to terminal .....300 V<sub>rms</sub>

Terminal to earth .....300 V<sub>rms</sub>

## Environment

Operating temperature .....0 to 50 °C

Storage temperature .....-20 to 70 °C

Relative humidity .....5% to 90% noncondensing

## Safety

Designed in accordance with IEC 61010-1, UL 3111-1, and CAN/CSA C22.2 No. 1010.1 for electrical measuring and test equipment.

Approved at altitudes up to 2000 meters.

Installation Category II

Pollution Degree 2

---

<sup>1</sup> The temperature sensor accuracy includes tolerances in all component values, effects caused by temperature and loading, and self-heating.

# Technical Support Resources

---

## NI Web Support

To provide you with immediate answers and solutions 24 hours a day, 365 days a year, National Instruments maintains extensive online technical support resources. They are available to you at no cost, are updated daily, and can be found in the Technical Support section of our Web site at [www.ni.com/support](http://www.ni.com/support)

## Worldwide Support

National Instruments has offices located around the globe. Many branch offices maintain a Web site to provide information on local services. You can access these Web sites from [www.ni.com/worldwide](http://www.ni.com/worldwide)

For telephone support in the United States, dial 512 795 8248. For telephone support outside the United States, contact your local branch office:

Australia 03 9879 5166, Austria 0662 45 79 90 0, Belgium 02 757 00 20, Brazil 011 284 5011, Canada (Calgary) 403 274 9391, Canada (Ontario) 905 785 0085, Canada (Québec) 514 694 8521, China 0755 3904939, Denmark 45 76 26 00, Finland 09 725 725 11, France 01 48 14 24 24, Germany 089 741 31 30, Greece 30 1 42 96 427, Hong Kong 2645 3186, India 91805275406, Israel 03 6120092, Italy 02 413091, Japan 03 5472 2970, Korea 02 596 7456, Mexico (D.F.) 5 280 7625, Mexico (Monterrey) 8 357 7695, Netherlands 0348 433466, Norway 32 27 73 00, Poland 48 22 528 94 06, Portugal 351 1 726 9011, Singapore 2265886, Spain 91 640 0085, Sweden 08 587 895 00, Switzerland 056 200 51 51, Taiwan 02 2377 1200, United Kingdom 01635 523545



321924B-01

Nov99